

# Power Pro<sup>®</sup>

CHLORINATION UNIT



**Westlake**  
Water Solutions

## The Accu-Tab® system PowerPro® chlorination unit is custom engineered to your individual requirements and automated for ease-of-use.

The Accu-Tab® system combines calcium hypochlorite tablets and chlorinators to provide a safer, simpler, and more accurate alternative to gas or bleach. The three-inch Accu-Tab SI (scale inhibitor) calcium hypochlorite tablets are specifically formulated to help prevent scale formation inside the chlorination chamber, especially in hard-water areas.

Because it's calcium hypochlorite-based, the compact PowerPro® unit does not require a separate entry building or room as is the case with chlorine gas, and it takes up a fraction of the space required for a similar bleach

system. As a result, the unit can be installed in smaller, more convenient locations, increasing operational efficiency and reducing chemical delivery problems.

PowerPro units are available in both gravity and pressure return models. They feature a simple "hook-up/plug-in" installation that expedites conversion from your old system. PowerPro units can be easily customized to meet your individual requirements and the compact size makes installation easy.



Accu-Tab system PowerPro 3075 chlorination unit shown with automated controller and weigh scale options.



PowerPro MD chlorination unit using Accu-Tab chlorinator model 3150 as shown.



PowerPro Gravity chlorination unit using Accu-Tab chlorinator model 3075 with digital flow meter as shown.

### PowerPro Chlorination Units Are:

- Safer, easy-to-use systems
- Accurate chlorination to 840 lbs/day/chlorinator
- Capable of treating 100 GPM to more than 20 MGD
- Reliable with minimum maintenance

### Features Include:

- UL listed
- Grundfos pumps
- Schedule 80 PVC piping
- Corrosion-resistant construction
- Custom engineered systems available to meet your requirements

### PowerPro Available Options:

- Residual control
- Flow proportion control
- Compound loop control
- Pressure regulator (required for 70 psi or greater)
- Field installed spare pump
- Installed weigh scale and low tablet alarm
- 50 Hz power\*\*
- SCADA compatible

| Model Number     | Chlorine Delivery Range (lbs/hr.) | Tablet Capacity (lbs.) | Unit Dimensions (WxLxH) | Solution Tank Capacity (US gal.) | Unit Inlet/Outlet Pipe Diameter |
|------------------|-----------------------------------|------------------------|-------------------------|----------------------------------|---------------------------------|
| 3012*            |                                   |                        |                         |                                  |                                 |
| PowerPro         | Up to 0.5                         | 12                     | 30" x 58" x 53"         | 22 gallon                        | 1.0"/1.0"                       |
| PowerPro Gravity | Up to 0.5                         | 12                     | 25" x 44" x 50"         | NA                               | 0.75"/1.5"                      |
| 3075*            |                                   |                        |                         |                                  |                                 |
| PowerPro         | 0.3-2.0                           | 75                     | 30" x 58" x 53"         | 22 gallon                        | 1.0"/1.0"                       |
| PowerPro MD      | 0.3-2.0                           | 75                     | 36" x 68" x 53"         | 69 gallon                        | 1.0"/1.0"                       |
| PowerPro Gravity | 0.3-2.0                           | 75                     | 25" x 44" x 53"         | NA                               | 1.0"/2.0"                       |
| 3150*            |                                   |                        |                         |                                  |                                 |
| PowerPro         | 1.0-12                            | 150                    | 30" x 58" x 53"         | 30 gallon                        | 1.5"/1.5"                       |
| PowerPro MD      | 1.0-12                            | 150                    | 36" x 68" x 59"         | 92 gallon                        | 1.5"/1.5"                       |
| PowerPro Gravity | 1.0-12                            | 150                    | 30" x 58" x 62"         | NA                               | 1.5"/3.0"                       |
| 3530*            |                                   |                        |                         |                                  |                                 |
| PowerPro         | 4.0-25                            |                        |                         |                                  |                                 |
| PowerPro MD      | 4.0-25                            | 300                    | 36" x 68" x 61"         | 45 gallon                        | 1.5"/1.5"                       |
| PowerPro MD      | 4.0-25                            | 300                    | 36" x 68" x 64"         | 92 gallon                        | 1.5"/1.5"                       |
| 30600            |                                   |                        |                         |                                  |                                 |
| PowerPro         | 10.0-35                           |                        |                         |                                  |                                 |
| PowerPro MD      | 10.0-35                           | 600                    | 36" x 68" x 56"         | 45 gallon                        | 1.5"/1.5"                       |
| PowerPro MD      | 10.0-35                           | 600                    | 36" x 68" x 63"         | 92 gallon                        | 1.5"/1.5"                       |
| 361000           |                                   |                        |                         |                                  |                                 |
| PowerPro         | 10.0-35                           | 1000                   | 41" x 76" x 61"         | 45 gallon                        | 1.5"/1.5"                       |
| PowerPro MD      | 10.0-35                           | 1000                   | 41" x 76" x 63"         | 92 gallon                        | 1.5"/1.5"                       |
| 481200           |                                   |                        |                         |                                  |                                 |
| PowerPro         |                                   | 1200                   | 54" x 87" x 64"         | 92 gallon                        | 1.5"/1.5"                       |
| PowerPro MD      | 10.0-35                           | 1200                   | 54" x 87" x 66"         | 230 gallon                       | 1.5"/1.5"                       |
| PowerPro Gravity | 10.0-35                           | 1200                   | 54" x 87" x 64"         | NA                               | 2.0"/4.0"                       |

\*Chlorinators are NSF Standard 61 certified.

\*\*220v 50hz power is available upon request.

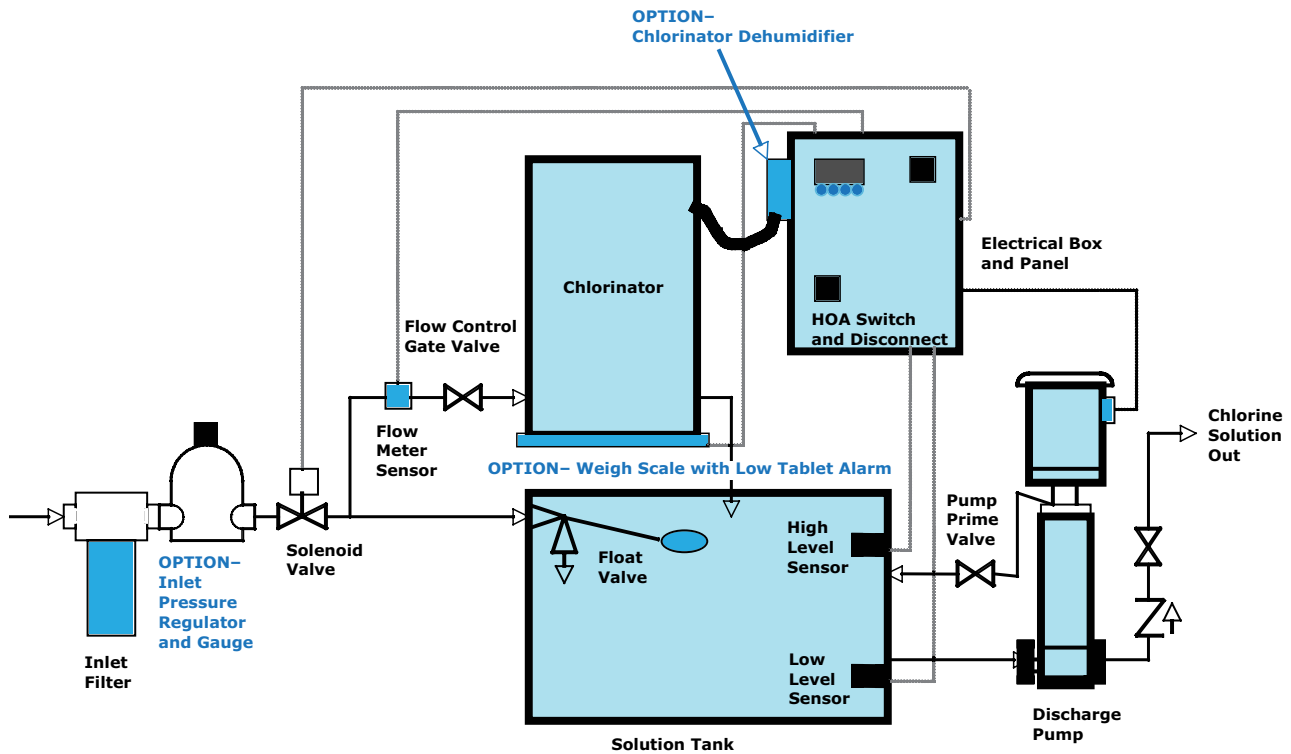

**Inlet Filter** – This is to prevent entrained debris from entering the chlorination system.

**OPTIONAL Pressure Regulator** – This is a required option when inlet water pressure is above 70 psi. It is to protect the float valve.

**Solenoid Valve** – The solenoid valve opens upon command of the plant signal to chlorinate. The solenoid will also close should a high level occur in the solution tank. The solenoid operates on 110V.

**OPTIONAL Digital Flow Meter** – A flow sensor transmits a pulse signal to a digital monitor. It measures the flow of fresh water entering the chlorinator to erode tablets. A 4-20mA signal for remote readout is available out of the electrical panel.

**Flow Control Gate Valve** – A PVC gate valve mounted in-line with the flow meter sensor to allow operator to manually adjust the flow of water to the chlorinator.

**Chlorinator** – Series 3000 chlorinators are available in various sizes.

**OPTIONAL Weigh Scale with Low Tablet Alarm** – Load cell platform under the chlorinator to monitor the weight of tablets in the chlorinator. A low tablet alarm is programmable, and a 4-20mA output is available.

**Solution Tank** – Made of medium density polyethylene. Capacities range from 22 gallons to 230 gallons depending on the chlorinator model used.

**Float Valve** – Made of PVC with a 316 SS rod and polyethylene ball. The valve meters bypass water flow. The purpose of this bypass stream is to balance the variation in the flow to the chlorinator with a constant pump discharge rate. As the flow rate to the chlorinator is adjusted, the float valve will open or close to maintain the same pump rate.

**High/Low Level Sensors** – The high level sensor will break the circuit to the solenoid valve, closing the valve, to prevent solution tank overflow. The low level sensor will break the signal to the pump contactor, shutting down the pump to prevent the pump from running dry. A timer on both sensors delays the restart to prevent system chattering.

**Discharge Pump** – Pumps the chlorine solution into a pressurized system. A multi-stage vertical Grundfos pump is used. Standard discharge pressure is 70 psi at maximum chlorinator feed rate.

**Pump Prime Valve** – Used to initially prime the pump, or when necessary. Also used during tank cleaning.

**Check Valve** – A ball check valve is used to prevent back flow into the system upon shut down.

**Discharge Flow Control Gate Valve** – A PVC gate valve is used to throttle discharge flow in order to balance the tank level. This is necessary when the pump output is greater than the amount of water that can be fed to the system.



Westlake Water Solutions  
 2801 Post Oak Blvd., Suite 600, Houston, TX 77056 USA  
[www.westlakewatersolutions.com](http://www.westlakewatersolutions.com)  
[WTPCustServ@westlake.com](mailto:WTPCustServ@westlake.com)

