



# Accu-Tab® Series 100 Chlorination System by Westlake Water Solutions

## Installation and Operating Instructions

**DANGER:**

**DO NOT MIX CHEMICALS!**

The Accu-Tab® Series 100 Chlorination System is designed for use with Westlake Water Solutions approved tablets only. Do not use Cal-Hypo tablets with stabilized chlorine or bromine products, or other sanitizing chemicals.

Fire or explosion could result.



Certified to  
NSF/ANSI/CAN 50

The Accu-Tab® Series 100 chlorination system is NSF/ANSI-Listed for pool and Spa applications. ONLY Westlake Water Solutions Accu-Tab® Blue SI Chlorinating Tablets for commercial pool and Spa applications are permitted for NSF installations. Use of other tablets will void NSF certification.

Revised 01-14-2025

## System Description

### Accu-Tab® Series 100 Chlorination System

The Accu-Tab® Series 100 Chlorination System incorporates a Westlake Water Solutions chlorinator, which is designed to utilize Westlake Water Solutions' Accu-Tab® Blue SI Chlorinating Tablets. Using a manually adjusted valve and flow meter, the amount of water through the chlorinator is controlled. This results in a constant and predictable rate of chlorine delivery. The chlorination system is designed for use ONLY with Westlake Water Solutions Accu-Tab® Blue SI Chlorinating Tablets to utilize the Westlake Water Solutions erosion feeder technology that erodes only the bottom layer of tablets on the sieve plate, while keeping tablets above the sieve plate dry and ready for use. Tablets other than Westlake Water Solutions Accu-Tab® Blue SI Chlorinating Tablets will have different delivery rates, resulting in improper chlorine delivery.



## Installation – Accu-Tab® Series 100 Chlorination System

### Figure 1 – Gravity Return

1. Place the chlorination system in a location near the place of application.
2. Level the system. This is important for proper delivery.
3. Install a Supply Service Valve off of the return line.
4. Install fittings, Flow Control Gate Valve, flow meter and filter to the inlet of the chlorinator body.
5. Using ½" pipe or tubing, connect from pool return to the flow meter.
6. Optional - A solenoid valve may be added in the inlet line for use with a chemical controller.
7. Using 1" pipe or tubing, connect the discharge to drain as needed. DO NOT RUN PIPE OR TUBING UPHILL.
8. Optional – A Discharge Service Valve may be added in the discharge line to facilitate cleaning.
9. Installation is now complete.

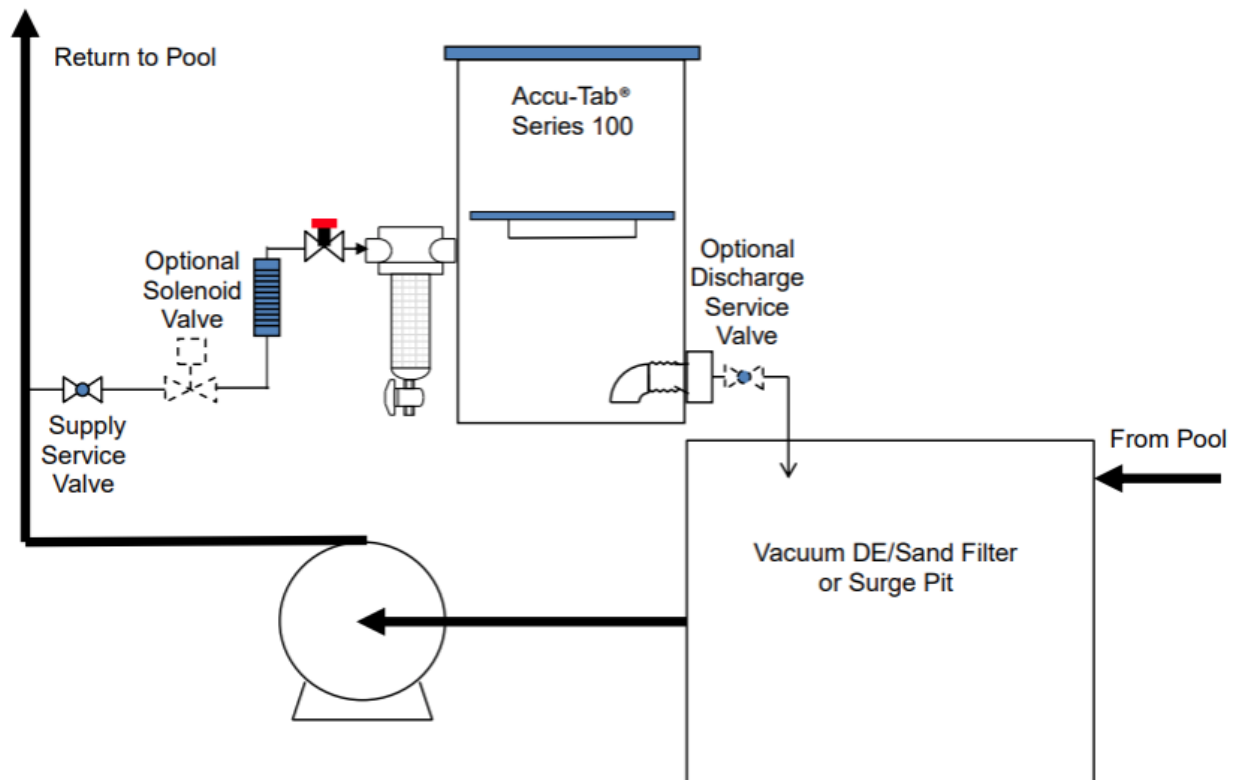

**FIGURE 1 – Accu-Tab® Series 100 Chlorination System Gravity Return Installation Example**

## Installation – Accu-Tab® Series 100 Chlorination System

### Figure 2 – Suction Return

NOTE: Pool re-circulation pump MUST be above the pool water level.

This installation MAY NOT be used with a Chemical Controller.

1. Place the chlorination system in a location near the place of application. Chlorinator MUST be above the pump.
2. Level the system. This is important for proper delivery.
3. Install the Flow Control Gate Valve to the discharge using the bushing and ½” nipple on discharge of chlorinator.
4. Install a Discharge Service Valve off of the pump suction line.
5. Using ½” pipe or tubing, connect the Flow Control Gate Valve to the Discharge Service Valve.
6. Install a Supply Service Valve off of the pump discharge line. Include the flow meter and filter.
7. Install fittings and flow meter to the inlet of the chlorinator body.
8. Using ½” pipe or tubing, connect from the pump discharge line (before the filter) to the flow meter.
9. Installation is now complete

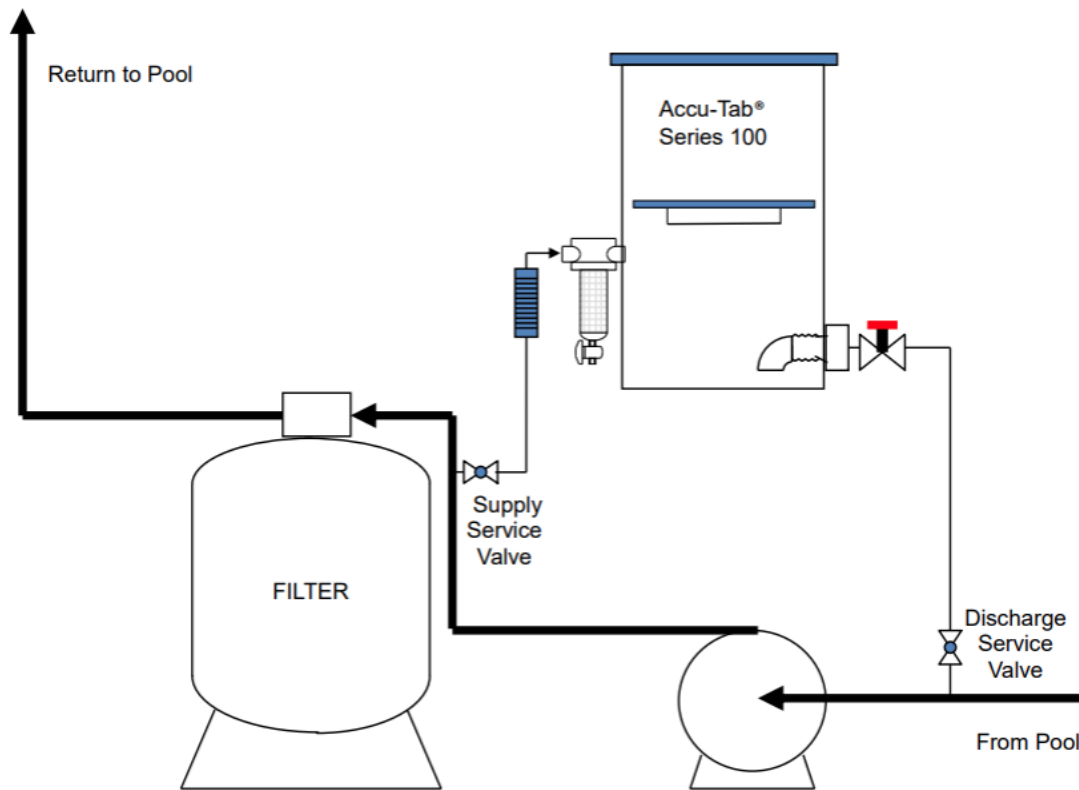
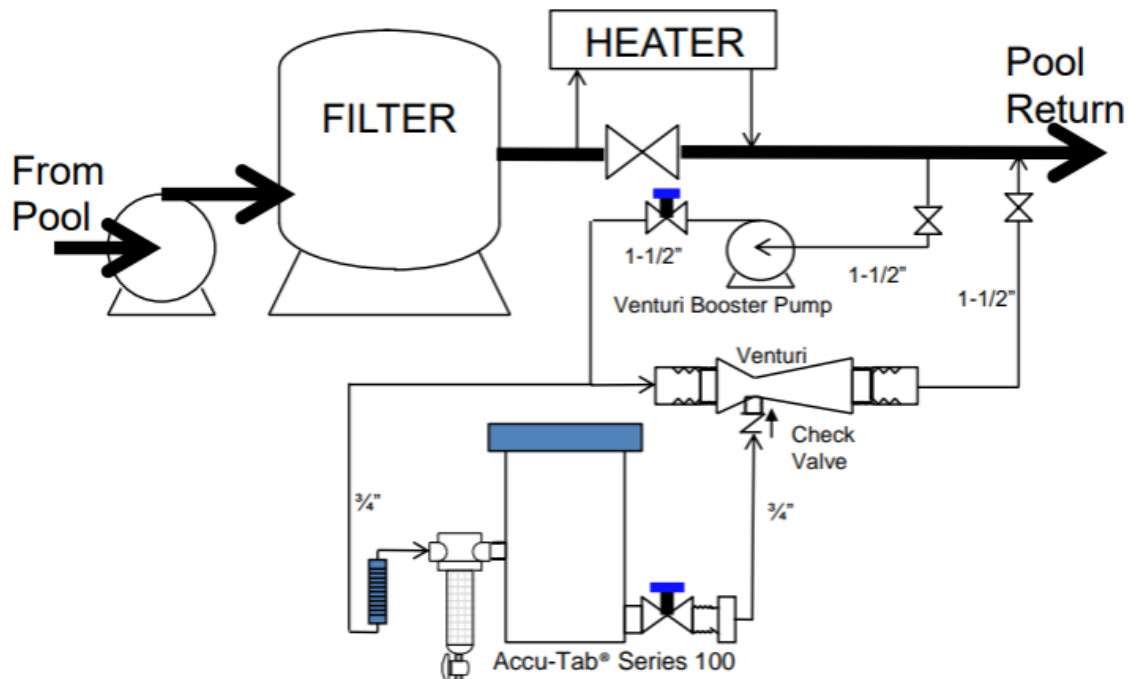

**FIGURE 2 – Accu-Tab® Series 100 Chlorination System  
Suction Return Installation Example**

## Installation – Accu-Tab® Series 100 Chlorination System

### Figure 3 – Forced Venturi Return (Kit available from Westlake SKU 9500154)

1. Place the chlorination system in a location near the place of application.
2. Level the system. This is important for proper delivery.
3. Install a Supply Service Valve off of the Pool return line.
4. Install a Discharge Service Valve off of the pump suction line.
5. Install fittings, flow meter and filter (filter MUST be installed at an angle) to the inlet of the chlorinator body.
6. Install Flow Control gate valve to the discharge of the chlorinator body.
7. Using 1½" pipe, plumb the pump and venturi loop following the kit instructions.
8. Using ¾" flex hose or piping, the chlorinator inlet and discharge lines as shown.
9. Installation is now complete.



**FIGURE 3 – Accu-Tab® Series 100 Chlorination System  
Forced Venturi Installation Example**

## Operation

### To refill the chlorinator

1. Remove the lid. (Be careful not to inhale fumes.)
2. Fill the chlorinator with Accu-Tab® Blue SI Chlorinating Tablets. Do not over fill.
3. Replace the lid.

### To operate the chlorinator

1. Start flow through the chlorinator. Important: For Suction Return - Open the supply service valve BEFORE opening the discharge service valve to assure water flow.
2. Adjust the control valve to the desired setting. Check Available Chlorine regularly to determine the best setting.
3. Adjust the control valve and refill the chlorinator as needed to maintain chlorine levels.

**Note:** When pool circulation stops, flow to the chlorinator will stop. This will stop chlorine delivery.

**Note:** In Gravity Return applications, the float valve will simply hang down and function as a fully open valve.

**Note:** In Suction Return applications, the float valve will function to keep a solution level in the chlorinator, preventing air from entering the pump suction.

## Cleaning

The chlorinator should be cleaned twice per year to remove any residual product that may accumulate inside the unit. Cleaning may be accomplished by soaking in a dilute acid solution. Addition of muriatic acid will lower the pH of the water. Be prepared to add a suitable pH increaser after cleaning is complete.

### Preparation for cleaning:

1. Prepare 2 Gallons of weak muriatic acid solution. Wear rubber gloves and rinse all equipment thoroughly when finished.
2. Have a clean, empty container for storage of any tablets inside the chlorinator.
3. Always use appropriate safety equipment while servicing the chlorinator or handling chemicals.

### To clean the chlorinator while installed:

1. Isolate the chlorinator from the system by closing both the discharge and supply service valves.
2. Remove the lid and remove all the tablets from the chlorinator. Temporarily place these tablets in the clean, empty container.
3. Rinse the chlorinator with water and (with the lid removed) open the discharge service valve temporarily to drain the chlorinator.
4. Close the discharge service valve and repeat step #3 once.
5. Close the discharge service valve and fill the chlorinator with water so there is about one inch of water above the sieve plate. Using rubber gloves and other safety protection, carefully pour the muriatic acid into the chlorinator including the walls of the chlorinator. ALWAYS ADD ACID TO WATER, NEVER ADD WATER TO ACID. Leave the lid removed and do not breathe any fumes. Let soak for 30 minutes.
6. After 30 minutes, open the discharge service valve. Open the supply service valve and flush the chlorinator for 30 minutes at 5 gpm.
7. After 30 minutes of flushing, isolate the chlorinator and rinse the walls with water. Drain the chlorinator by temporarily opening the discharge service valve. Rinse a second time and drain.
8. Cleaning is now complete.

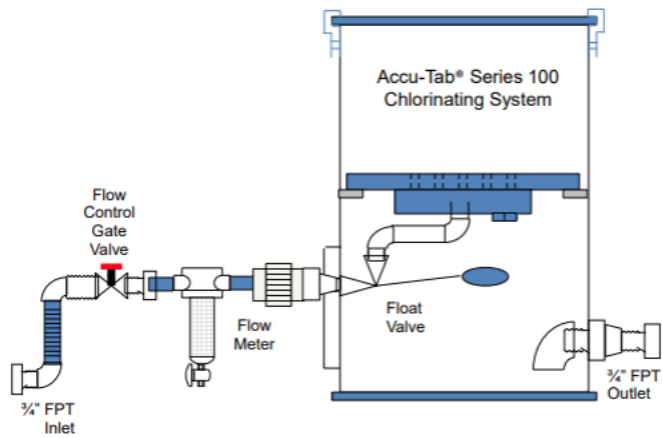
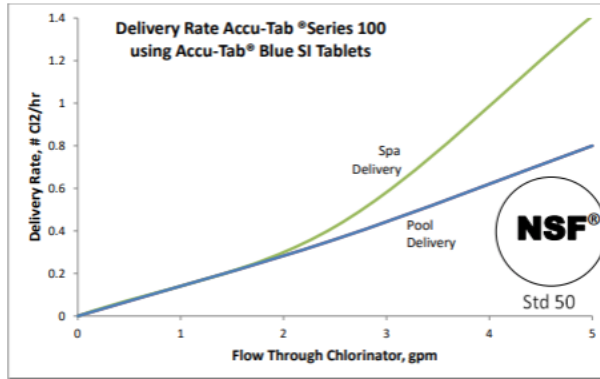

System Schematic - Accu-Tab® Series 100 Chlorination System when using Gravity Return

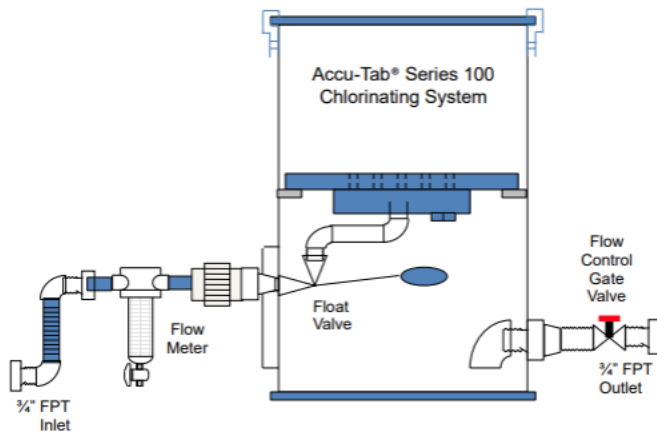

System Schematic - Accu-Tab® Series 100 Chlorination System when using Suction and Forced Venturi Return

### **CAL-HYPO COMMERCIAL SYSTEM LIMITED WARRANTY**

Westlake Water Solutions warrants (subject to the below conditions) only its title to this water treatment system equipment (the "System") and that the System will be free of defects in materials and workmanship for a period of eighteen (18) months from its original shipment date.

THIS IS THE ONLY REPRESENTATION OR EXPRESS WARRANTY THAT WESTLAKE WATER SOLUTIONS MAKES AND ALL OTHER EXPRESS WARRANTIES UNDER STATUTE OR ARISING OTHERWISE IN LAW FROM A COURSE OF DEALING OR USAGE OF TRADE WITH RESPECT TO THE SYSTEM ARE DISCLAIMED. ANY IMPLIED WARRANTIES EXISTING AS A MATTER OF LAW SHALL NOT EXCEED THE DURATION OF THIS LIMITED WARRANTY. IN THE EVENT THE SYSTEM FAILS TO CONFORM TO THIS WARRANTY, WESTLAKE WATER SOLUTIONS EXCLUSIVE OBLIGATION AND YOUR EXCLUSIVE REMEDY SHALL BE LIMITED TO, AT WESTLAKE WATER SOLUTIONS OPTION, THE FURNISHING OF NEEDED REPLACEMENT PARTS OR THE FURNISHING OF A NEW SYSTEM (BUT THIS DOES NOT INCLUDE INSTALLATION OR THE COSTS FOR INSTALLATION). EXCEPT AS PROVIDED IN THE IMMEDIATELY PRECEDING SENTENCE, IN NO EVENT WILL WESTLAKE WATER SOLUTIONS BE LIABLE UNDER ANY THEORY OF RECOVERY (WHETHER BASED ON NEGLIGENCE OF ANY KIND, STRICT LIABILITY OR TORT) FOR ANY DIRECT, INDIRECT, SPECIAL, INCIDENTAL, PUNITIVE, OR CONSEQUENTIAL DAMAGES IN ANY WAY RELATED TO ANY USE MADE OF THE SYSTEM.

Warranty Conditions. This Limited Warranty shall apply and be effective only if: (i) the System is installed and operated and maintained in accordance with this manual and the instructions accompanying the System; (ii) you, at your cost, promptly return the System or defective part to such location as may be specified by Westlake Water Solutions; and, (iii) only Westlake Water Solutions Accu-Tab® Blue SI calcium hypochlorite tablets are used in the System. If any of these conditions are not met, this Limited Warranty will not apply and you acknowledge and agree that your purchase of the System will be on an "AS-IS" basis without any warranty of any kind whatsoever having been provided by Westlake Water Solutions.

You assume all responsibility and risk and liability arising from: (i) the unloading, installation, storage, handling and use of the System, including use thereof alone or in combination with other materials; (ii) the improper functioning or failure of unloading, installation, transportation or storage equipment you use, whether furnished or recommended by Westlake Water Solutions or not; and, (iii) the failure to comply with laws, rules and regulations governing storage, unloading, installation, handling, and use of the System. You will indemnify, hold harmless, and defend Westlake Water Solutions from and against any claim, suit, damage, cost, expense, fine, liability, or cause of action whatsoever, including reasonable attorney fees, on account of relating to, or arising out of the use, possession, installation or resale of the System.

This Limited Warranty gives you specific rights, and you also may have other rights, which vary from jurisdiction to jurisdiction. Some jurisdictions do not allow the exclusion or limitation of incidental or consequential damages, so the above limitations or exclusions may not apply to you. Some jurisdictions do not allow limitations on how long an implied warranty lasts, so the above limitation may not apply to you.

©2025 Westlake Water Solutions. Accu-Tab is a registered trademark of Westlake.  
Westlake Water Solutions 2801 Post Oak Blvd., Suite 600, Houston, TX 77056 USA  
**[www.westlakewatersolutions.com](http://www.westlakewatersolutions.com)**  
**Technical Support: 855-934-3570**

Disclaimer: The information presented herein is for general informational purposes only. Products are subject to standard terms and conditions of sale, which are available upon request. No warranty, express or implied, including, but not limited to, any warranty of merchantability or fitness for a particular purpose, is made, and any and all warranties on such products are limited to those expressly set forth in the applicable entity's standard terms and conditions. Any reliance the user places on the information presented here is strictly at the user's own risk.