

Acid- Rite® 450 Feeder

Installation and Operating Instructions



Certified to
NSF/ANSI/CAN 50

The Acid-Rite 450 Feeder is NSF-Listed for pool and spa applications. ONLY Westlake Water Solutions, Acid-Rite Sodium Bisulfate Tablets are permitted for NSF installations. Use of other tablets will void NSF certification.

DANGER:

DO NOT MIX CHEMICALS!

The Acid-Rite® pH Adjustment System is designed for use with Westlake Water Solutions Acid- Rite® tablets only.

DO NOT USE ANY OTHER TABLETS. User negligence could result in serious risks to health and safety.

Revised 1-14-2025

System Description

Acid-Rite® 450 Feeder

The Acid-Rite® 450 Feeder incorporates a Feeder that will accurately and reliably add a pH adjustment chemical to your water system. The system also incorporates a level controlled solution tank and pump to deliver the acid solution to the return line.

The design allows only the lower tablets to be wetted and dissolved while the tablets above remain drier.

ONLY use Westlake Water Solutions Acid-Rite® tablets. Use of other tablets will void the warranty, void the NSF Certification and could increase risks to health and safety.



Installation (Figure 1)

NOTE: When this Acid-Rite® system is being installed in conjunction with a Calcium Hypochlorite based sanitizer system such as Accu-Tab®, be sure the take-off for the water supply line to the Acid-Rite® feeder is installed prior to injection of the sanitizer discharge back into the water delivery loop. Failure to do this could result in release of Chlorine gas. See Figure 2 for a block flow example of an Acid-Rite® system installation when a Accu-Tab® sanitizer system is included.

1. Mount the Feeder on a level surface. Bolts/nuts are provided for leveling.
2. Assemble inlet fitting to the Filter. NOTE flow direction.
3. Thread the inlet filter to the float valve nozzle.
4. Assemble elbow and drain valve on the filter bottom.
5. Assemble the flow meter assembly to the feeder using the pipe unions. NOTE flow direction. This was shipped separately to prevent breakage in shipment.
6. Use 1" piping or hose to connect from Return Line water supply to the feeder. Include a block valve.
7. Assemble discharge piping to the pump. The Check/Gate valve assembly (note flow direction) and other supplied parts were shipped separately to allow options in discharge piping.
8. Install the supplied 1" Ball Check Valve on the discharge line. This must be on a vertical run of pipe after the flap check valve assembly. Pay attention to valve orientation, flow direction should be upward and away from the system.
9. Use 1" piping or hose from discharge to connect to Return Line delivery point AFTER the heater.
10. Plug in the Power and Controller cords.
11. Test run system. Repair any leaks.

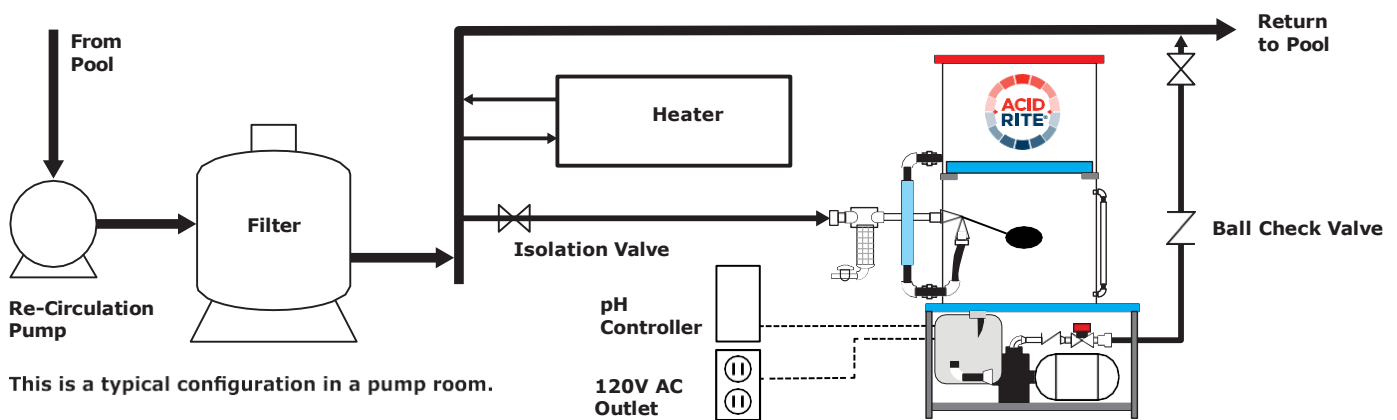

Figure 1 - Installation

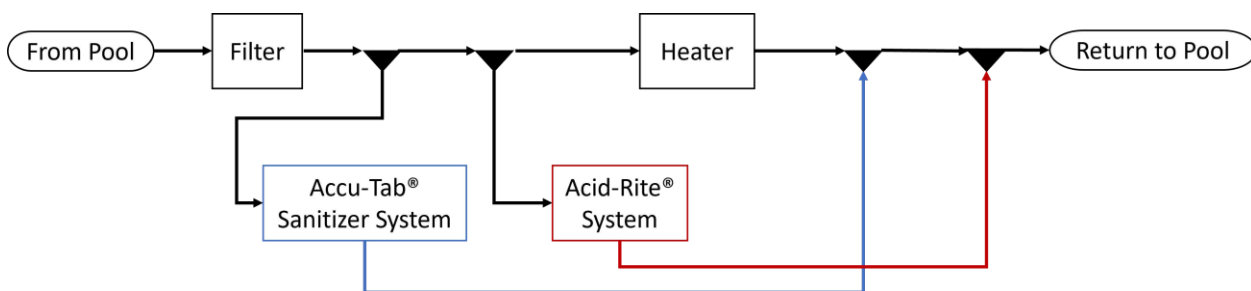

Figure 2 - Block Flow Ex. When Installed with Accu-Tab® Sanitizer System

Start-Up Instructions

1. Open inlet and outlet block valves. Water will flow through the feeder and fill the solution tank.
2. When inlet water stops flowing, open the Discharge Control valve a 2-3 turns.
3. Start pump with controller, and set flow at 1-2 gpm.
4. Shut down system, to prevent acid splashing while tablets are added.
5. Add *Acid-Rite* tablets to feeder.
6. Start system using the controller to add acid to pool/spa.
7. Monitor pH of pool/spa and adjust flow through feeder as needed.

Operation Instructions

1. Remove lid from Acid-Rite® 450 Feeder.
2. Add Acid-Rite pH Adjusting Tablets to the feeder.
3. Replace lid.
4. Check pH of water system and adjust flow as necessary.

WARNING: Addition of acid without pool circulation can result in chlorine gas release. Always have the feeder interlocked with a no flow circulation system condition.

NOTE: When pool water circulation stops, flow to the feeder will stop. This will stop acid delivery.

NOTE: Minimum flow through feeder is 0.5 gpm.

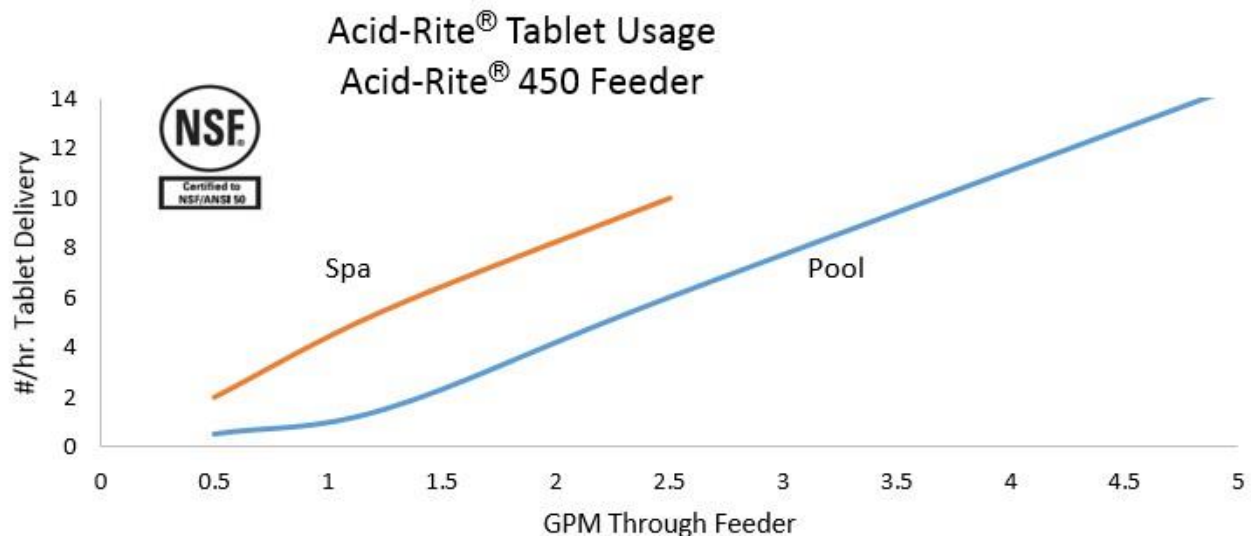

System Overflows

1. Check for debris in the float valve.
2. Check for debris in the check valve.
3. Float valve stuck in down position. Clean float valve. DO NOT use any lubricant on the valve internals.

Pump will not run.

1. Check power supply and connections, and controller 120v signal.
2. Check for 120 voltage across terminals #2 and #5. If voltage present, wiring or pump motor failure.
3. If no voltage, check pump contactor.

Pump loses prime (solution tank empties and refills)

Maximum inlet flow exceeded. To determine the maximum inlet flow rate, start by closing the discharge gate valve. Open the discharge gate valve in small increments. Remember to allow a few minutes each time to allow the flow meter to stabilize. If pump loses prime, maximum inlet flow has been exceeded. Shut down system for a few minutes (which will prime the pump), close back on the discharge gate valve and restart the system. Continue this process until the maximum inlet flow is determined.

Float Valve maintenance

If valve becomes clogged with debris on a continuing basis, add a second filter to the inlet. Use the 60 mesh in the first filter then a 100 mesh in the second. The 100 mesh filter can be supplied by your specialist.

Cleaning

Over time and when the system is not highly used, some residue/build-up may float on the solution surface in the solution tank or collect on the walls or float valve ball. Wiping up and disposing of this residue in the trash is sufficient cleaning.

Should cleaning be necessary, refer to the Safety Data Sheet for use of Personal Protective Equipment for handling acid solutions.

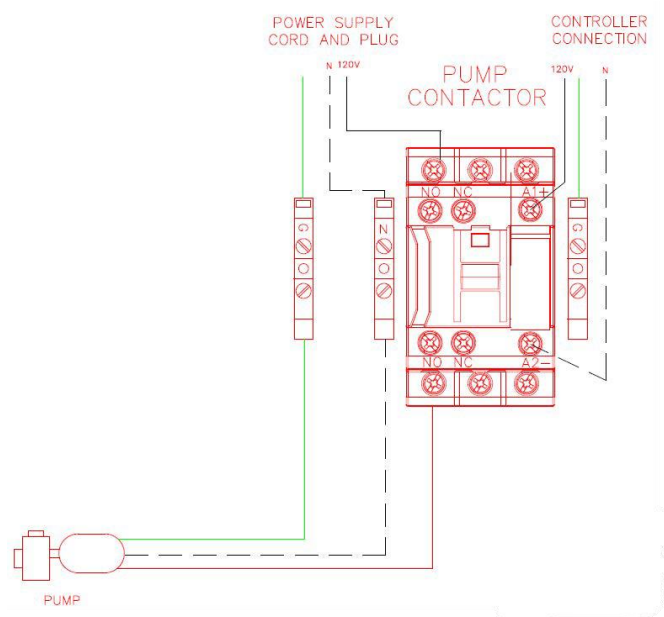

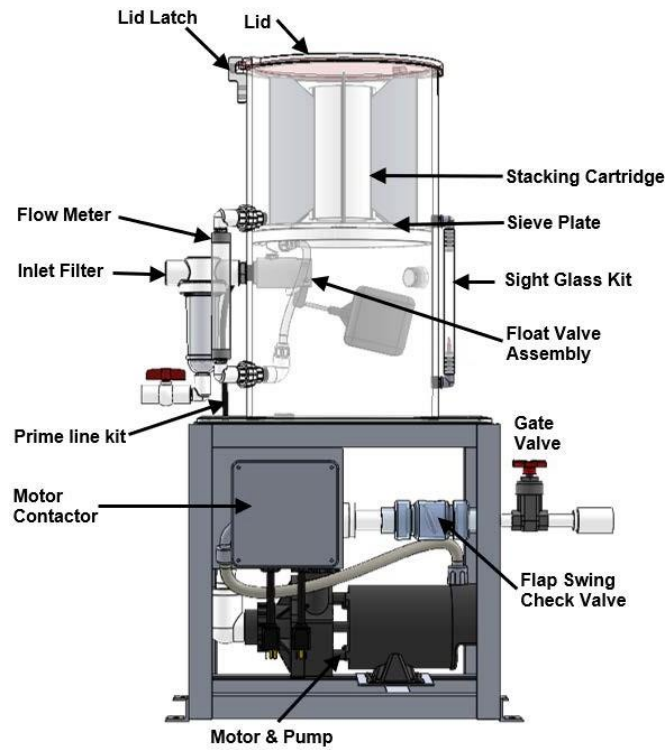

Acid-Rite® 450 Unit Diagram

ACID-RITE® SYSTEM LIMITED WARRANTY

Westlake Water Solutions warrants (subject to the below conditions) only its title to this water treatment system equipment (the "System") and that the System will be free of defects in materials and workmanship for a period of eighteen (18) months from its original shipment date.

THIS IS THE ONLY REPRESENTATION OR EXPRESS WARRANTY THAT WESTLAKE WATER SOLUTIONS MAKES AND ALL OTHER EXPRESS WARRANTIES UNDER STATUTE OR ARISING OTHERWISE IN LAW FROM A COURSE OF DEALING OR USAGE OF TRADE WITH RESPECT TO THE SYSTEM ARE DISCLAIMED. ANY IMPLIED WARRANTIES EXISTING AS A MATTER OF LAW SHALL NOT EXCEED THE DURATION OF THIS LIMITED WARRANTY. IN THE EVENT THE SYSTEM FAILS TO CONFORM TO THIS WARRANTY, WESTLAKE WATER SOLUTIONS EXCLUSIVE OBLIGATION AND YOUR EXCLUSIVE REMEDY SHALL BE LIMITED TO, AT WESTLAKE WATER SOLUTIONS OPTION, THE FURNISHING OF NEEDED REPLACEMENT PARTS OR THE FURNISHING OF A NEW SYSTEM (BUT THIS DOES NOT INCLUDE INSTALLATION OR THE COSTS FOR INSTALLATION). EXCEPT AS PROVIDED IN THE IMMEDIATELY PRECEDING SENTENCE, IN NO EVENT WILL WESTLAKE WATER SOLUTIONS BE LIABLE UNDER ANY THEORY OF RECOVERY (WHETHER BASED ON NEGLIGENCE OF ANY KIND, STRICT LIABILITY OR TORT) FOR ANY DIRECT, INDIRECT, SPECIAL, INCIDENTAL, PUNITIVE, OR CONSEQUENTIAL DAMAGES IN ANY WAY RELATED TO ANY USE MADE OF THE SYSTEM.

Warranty Conditions. This Limited Warranty shall apply and be effective only if: (i) the System is installed and operated and maintained in accordance with this manual and the instructions accompanying the System;

(ii) you, at your cost, promptly return the System or defective part to such location as may be specified by Westlake Water Solutions; and, (iii) only West Lake Water Solutions Acid-Rite sodium bisulfate tablets are used in the System. If any of these conditions are not met, this Limited Warranty will not apply and you acknowledge and agree that your purchase of the System will be on an "AS-IS" basis without any warranty of any kind whatsoever having been provided by Westlake Water Solutions.

You assume all responsibility and risk and liability arising from: (i) the unloading, installation, storage, handling and use of the System, including use thereof alone or in combination with other materials; (ii) the improper functioning or failure of unloading, installation, transportation or storage equipment you use, whether furnished or recommended by Westlake Water Solutions or not; and, (iii) the failure to comply with laws, rules and regulations governing storage, unloading, installation, handling, and use of the System. You will indemnify, hold harmless, and defend Westlake Water Solutions from and against any claim, suit, damage, cost, expense, fine, liability, or cause of action whatsoever, including reasonable attorney fees, on account of relating to, or arising out of the use, possession, installation or resale of the System.

This Limited Warranty gives you specific rights, and you also may have other rights, which vary from jurisdiction to jurisdiction. Some jurisdictions do not allow the exclusion or limitation of incidental or consequential damages, so the above limitations or exclusions may not apply to you. Some jurisdictions do not allow limitations on how long an implied warranty lasts, so the above limitation may not apply to you.

©2025 Westlake Water Solutions. Acid-Rite is a registered trademark of Westlake.

Westlake Water Solutions
2801 Post Oak Blvd., Suite 600, Houston, TX 77056 USA
www.westlakewatersolutions.com
Technical Support: 855-934-3570

*220v 50hz power is available upon request

Disclaimer: The information presented herein is for general informational purposes only. Products are subject to standard terms and conditions of sale, which are available upon request. No warranty, express or implied, including, but not limited to, any warranty of merchantability or fitness for a particular purpose, is made, and any and all warranties on such products are limited to those expressly set forth in the applicable entity's standard terms and conditions. Any reliance the user places on the information presented here is strictly at the user's own risk.