

Acid-Rite® 450

Water pH Adjustment System



Compact pH Adjustment System Conquers Pump Room Size Limitations



Certified to NSF/ANSI/CAN 50

- Uses patented red sodium bisulfate tablets
- Enhances chlorine efficacy in water
- Low odor
- Low maintenance
- Controllable adjustment
- Footprint of Unit:
14" D x 22" W x 44" H

A compact and effective alternative to bulky liquid acid systems. Utilizing patented red Acid-Rite sodium bisulfate tablets, the feeder system fits easily into the pump room making it a convenient and more manageable option

Call 1.800.245.2974 for a free consultation



Stacking cartridge included for additional dial-in capability.



Westlake
Water Solutions

Acid-Rite Water Adjustment System Installation and Specification

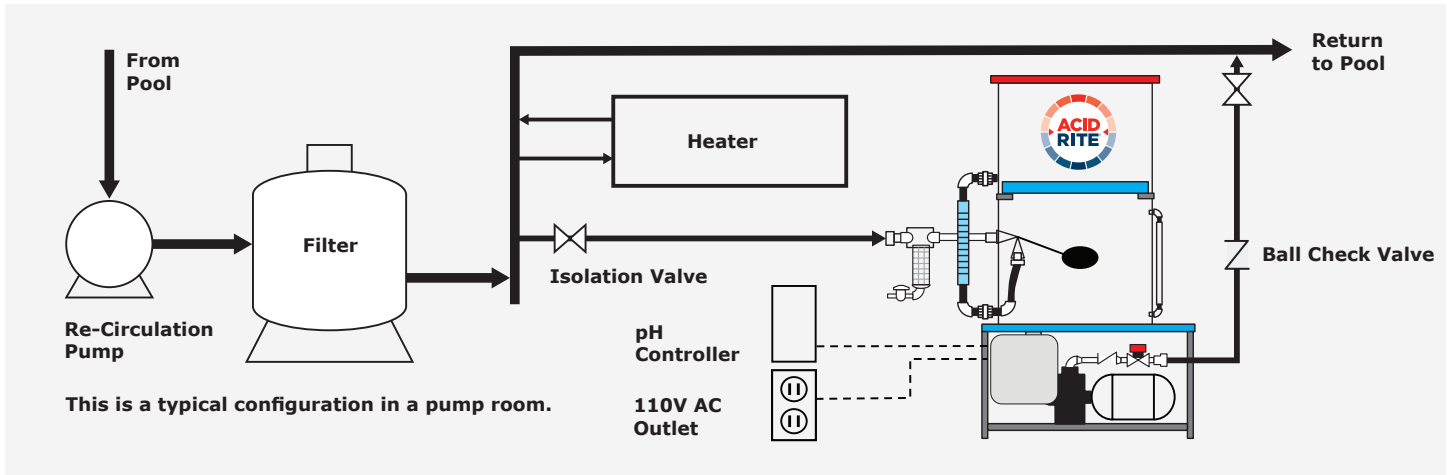

Pool Size

- Inside: up to 300,000 gallons
- Outside: up to 200,000 gallons

Acid-Rite Unit Size







- Flow Rate: 0–5 gpm
- Tablet Capacity: up to 45 lbs
- Supply/Discharge Pipe Size: 1"

Patented Acid-Rite Tablets

- 99.97% Sodium Bisulfate
- 3" diameter
- Red color for safety
- 45-lb pails

No metering. No mixing. No contest.

Lightens the load on pool operators from safety, handling and maintenance, to creating a pleasant workplace environment. See for yourself.

	Safety 	Handling 	Maintenance 	Material Compatibility and Corrosivity 
Acid-Rite® 	Solid chemical made of sodium bisulfate with no dual containment	Easier to handle 45-lb resealable pails	Acid feeders rarely require cleaning or maintenance; no small tubing that can kink and crack	Tablets have low odor and are red in color to help eliminate inadvertent mixing of chemicals
Muriatic Acid 	Strong odor/fuming; potential liquid spills	55-gal drums weigh more than 500 lbs	Feed pumps need frequent repair and tubing can leak	Strong corrosive liquid with strong noticeable odor; leaking tubes or feed pumps can attack equipment room
Granular Sodium Bisulfate 	Bags are difficult to cut and empty; powder can accumulate on surfaces	50 lbs bags are awkward and difficult to handle, not resealable	Feed pumps need constant repair and tubes plug regularly; mixing motors fail	Powdered acid and leaking tubes can attack mixing motors and equipment



Westlake Water Solutions
 2801 Post Oak Blvd., Suite 600, Houston, TX 77056 USA
www.westlakewatersolutions.com
WTPCustServ@westlake.com

