

Accu-Tab[®] PowerBase[®] 1030 by Axiall Corporation

Installation and Operating Instructions



STD 50

The PowerBase[®] 1030 Chlorinator is

NSF-Listed for pool and spa applications.

ONLY Axiall Corp. Accu-Tab[®] Blue SI
Tablets for commercial pool applications
are permitted for NSF installations.
Use of tablets will void NSF certification.

DANGER:

DO NOT MIX CHEMICALS!

The PowerBase 1030 chlorinator system is designed for use with Axiall Corp. approved tablets only. Do not use Cal-Hypo tablets with stabilized chlorine or bromine products, or other sanitizing chemicals. Fire or explosion could result.

Rev 06/11/15

Description

The *Accu-Tab PowerBase* 1030 chlorination system incorporates an Axial Corporation chlorinator. Included in the system is an integrated, level controlled solution tank, which supplies a centrifugal pump. The flow rate through the system is controlled by a manually adjusted valve on the discharge of the pump. The solution tank level is controlled by a float valve. As solution is pulled from the tank, the float valve opens allowing water to flow to the chlorinator, contacting the tablets, and then into the solution tank. Overflow protection is standard. Two level switches in the top area of the Solution Tank will cause the pump to turn on/off as needed.

The chlorination system is designed for use ONLY with Axial *Accu-Tab* Blue SI tablets utilizing the Axial erosion feeder technology that erodes only the bottom layer of tablets on the sieve plate, while keeping tablets above the sieve plate dry and ready for use. Tablets other than Axial *Accu-Tab* Blue SI tablets will have different delivery rates, resulting in improper chlorine delivery.



Installation Instructions

1. Place the chlorination system in a location near the place of application.
2. Level the system. This is important for proper delivery.
3. The float ball and rod, and the float valve discharge piping were shipped loose to prevent breakage in shipment. Install float ball and insert, but do not cement the piping. When placing the chlorinator top onto the solution stock take care to line up the piping to prevent breaking the piping or valve.
4. Install a pressure regulator on the inlet supply line IF inlet line pressure is greater than 20 psi. Tank flooding will result if pressure exceeds 20 psi.
5. Connect the inlet water supply with 1" (25.4 mm) PVC pipe or hose. Include an isolation valve in the line. A flow meter should be installed on the inlet line to monitor and control flow. (**Note:** the inlet fitting is ¾" thread)
6. Connect the supplied check valve and discharge gate valve on the pump discharge.
7. Connect the discharge piping from the feeder, to the chlorine application point, with 1" (25.4 mm) PVC pipe or hose. Include an isolation valve in the line.
8. Plug the power cord into a 110v receptacle.
9. Assure that the circuit breaker inside the electrical box is switched "ON".
10. If a chemical controller is utilized, plug the controller cord into the controller's 110v switched output. If system is to be run manually, install jumpers as shown in the electrical schematic.

Installation example

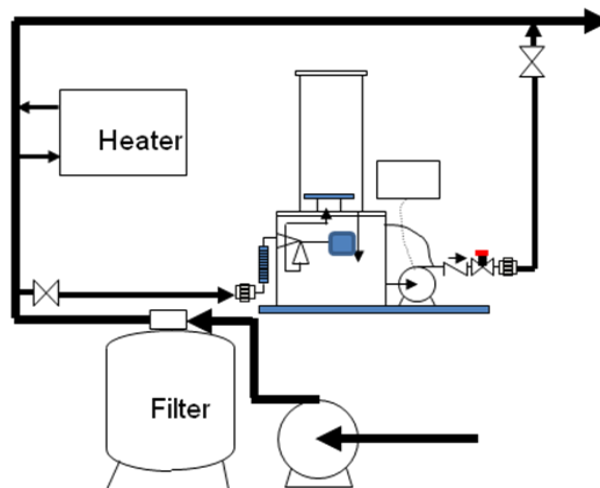

The pressure regulator is required on the inlet if the supply water pressure is greater than 20 psi. Float valve will leak through above 20 psi, resulting in the solution tank overflowing.

Start-Up

1. Close the discharge gate valve.
2. Open the feed and discharge isolation valves. Water will begin to fill the solution tank.
3. Adjust pressure regulator (if required) to 20 psi or lower. This adjustment should be done as the water is flowing, and checked to be sure no water is flowing when the float valve lifts.
4. When water stops flowing, switch the system on using the chemical controller. The pump will circulate water through the blue tubing.
5. Begin opening the discharge gate valve to start flow to the system.
6. Determine maximum inlet flow rate when the filter is dirty. Complete this by continuing to open the discharge gate valve in small increments. Remember to allow a few minutes each time for the flow meter to stabilize. If pump loses prime, the maximum inlet flow has been exceeded. Shut down the system for a few minutes (which will prime the pump), close back on the discharge valve and restart the system. Continue this process until the maximum inlet flow is determined. This flow rate should not be exceeded in normal operation.
7. Adjust flow through feeder using the discharge gate valve. The chlorine delivery is determined by the flow rate through the chlorinator. Use the graph below to determine proper flow rate. NOTE: After adjusting the discharge valve, the flow meter will take a few moments to stabilize.
8. Check all piping for leaks.

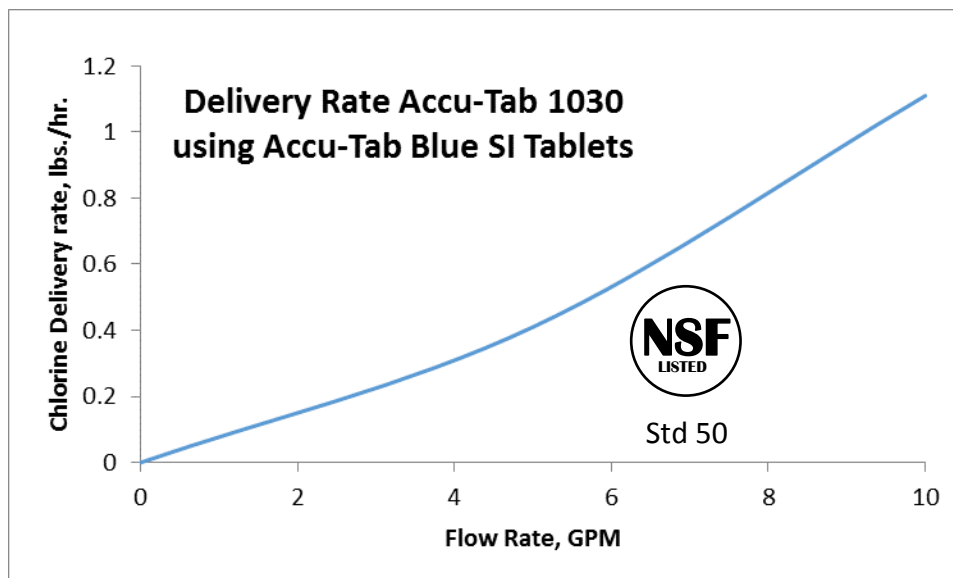

Operation

1. Remove lid from chlorinator and fill with the appropriate amount of Axiall Corporation *Accu-Tab* Blue SI tablets.
2. Tablets **MUST** be single stacked in each quadrant of the feeder for proper operation.
3. Check pool water for desired chlorine level and adjust flow through chlorinator as needed.

NOTE: When pool water circulation stops, flow to chlorinator will stop.
This will stop chlorine delivery.

Adding Tablets

1. Tablets may be added while the system is running. Take care to protect eyes, skin, clothing and other equipment from splashing. Do not inhale fumes.
2. Remove lid and fill with *Accu-Tab* Blue SI tablets.
3. Replace lid.

Maintenance

- A. Clean the Check Valve at least every 4-6 months, to remove debris or scale.
- B. System Cleaning

Over time the chlorination system may develop a build-up of scale. This should be cleaned on a periodic basis, approximately twice per year. If scale formation is severe, more frequent cleanings may be necessary. Cleaning may be accomplished by soaking the feeder with a dilute acid solution according to the instructions below.

NOTE: Addition of muriatic acid will lower the pH of the water.

Preparation for cleaning

1. Prepare 2 gallons of muriatic acid.
2. **Always use** appropriate safety equipment while servicing the unit or handling chemicals.
3. Clean the feeder in a well-ventilated area. Chlorine gas may be released during the cleaning process!

Cleaning procedure

1. Turn system off.
2. Open lid and remove all tablets. Use proper protective equipment when handling chemicals.
3. Switch system on to begin flushing the system.
4. Wash out the feeder with a hose to remove remnants of tablets and loosen scale.
5. Operate system until normal solution tank level is achieved. Switch system off.
6. Close inlet and outlet isolation valves.
7. Very carefully, pour the acid into the upper chlorinator to dissolve scale. It may be necessary to pour directly on the inside walls to remove any scale above the water level. **Always add acid to water, never add water to acid.**
8. Let soak for 30 minutes. As acid dissolves scale, carbon dioxide will be released, and foaming will occur. If any tablets were left in the feeder, **chlorine gas may also be released.**
9. Turn system on to start acid circulation through the blue tubing. Circulate for 10 minutes.
10. Open all valves to begin purging acid from system.
11. Wash the walls and sieve plate of the feeder with a hose to remove all acid residue. Chlorine gas may be released if any acid remains in the system.
12. Allow feeder to flush water for 30 minutes.
13. Turn system off. System is ready for operation.

Troubleshooting

1. System overflows.
 - A. Incoming pressure is higher than 20 psi. Reduce pressure.
 - B. Debris in the float valve.
 - C. Debris in the check valve.
2. Pump will not run.
 - A. Check power supply and connections.
 - B. Circuit breaker tripped. Reset breaker.
 - C. Check for 110 voltage across terminals #2 and #5. If voltage present, wiring or pump motor failure.
3. Pump loses prime.
 - A. Maximum inlet flow exceeded. See **Start-Up** instructions – point #6.

Chlorinator Top Orientation

Align the chlorinator top portion so that the pointer on the separation plate is directly over the inlet – see photo below. This will prevent chlorine solution from draining directly onto the float valve assembly.

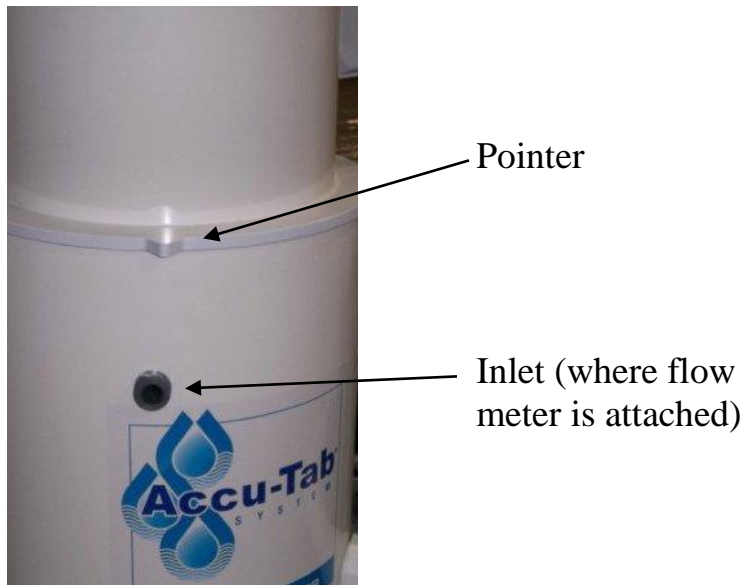

System Schematic

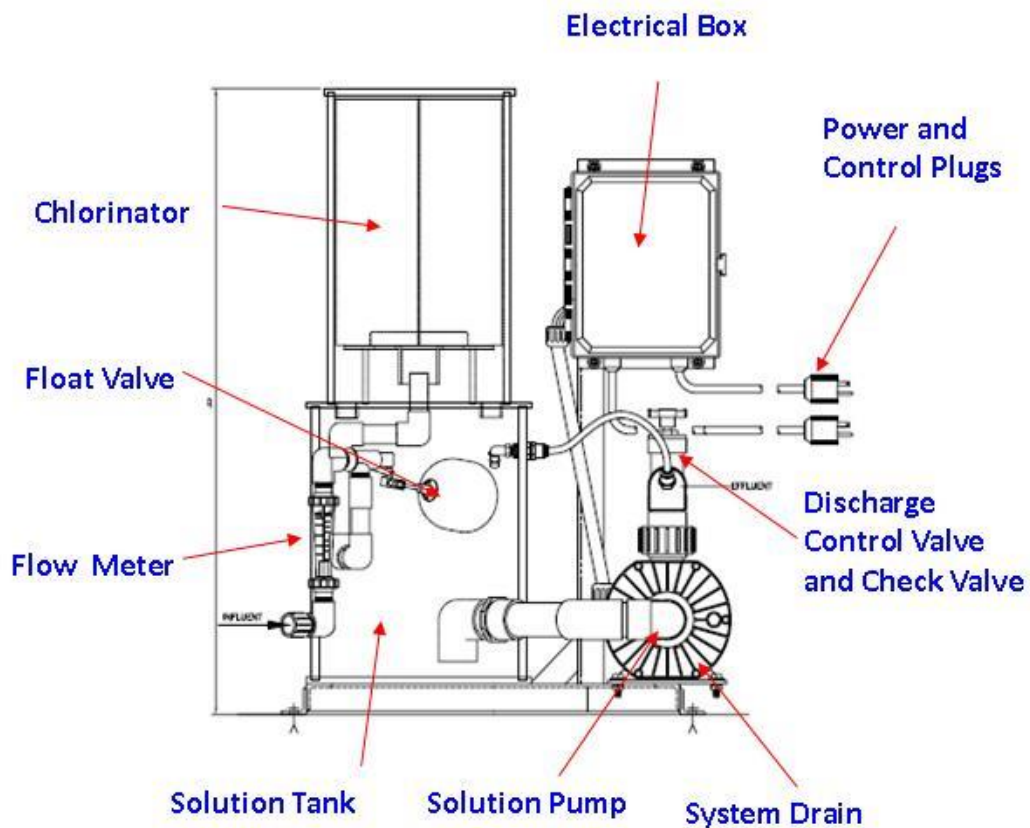

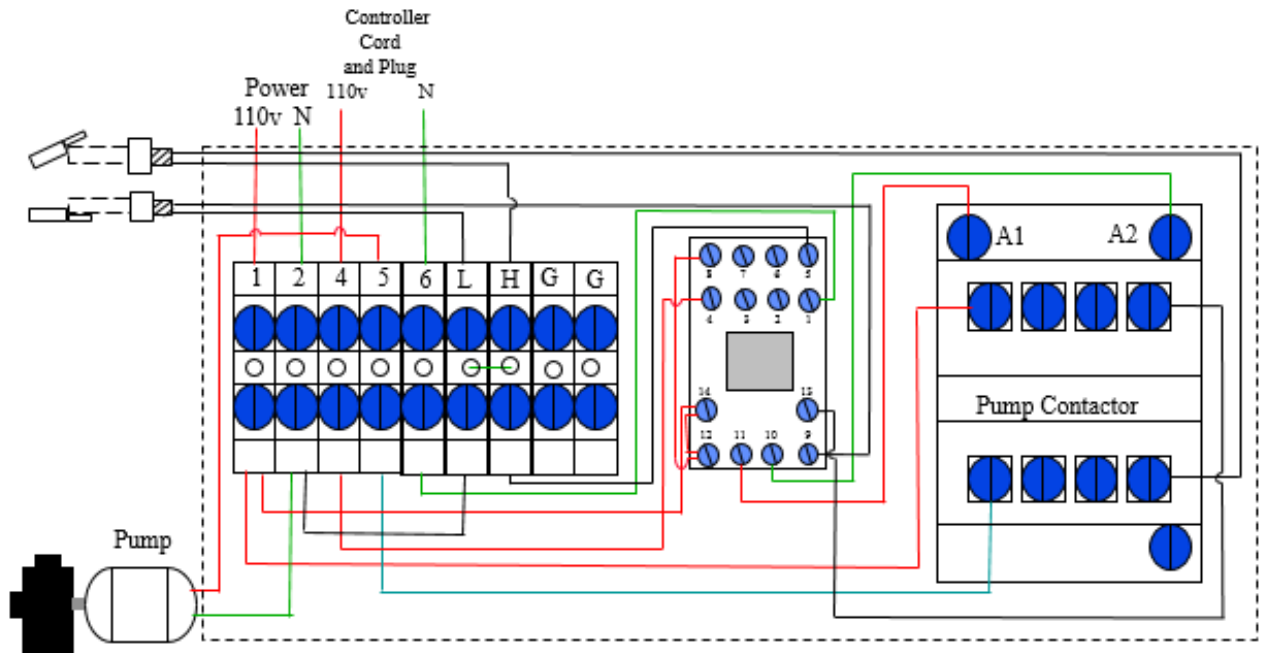

Electrical Drawing Base System

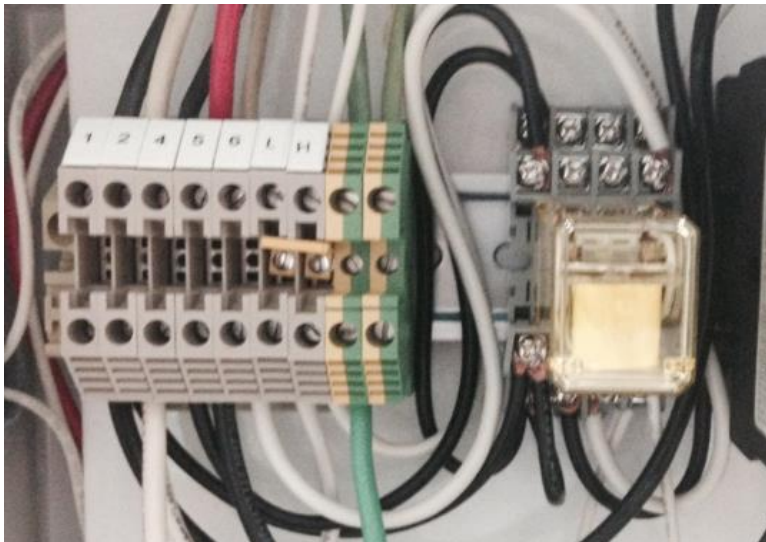

If a chemical controller is not used, remove control cord and install jumpers between:
Terminal #1 & #4
Terminal #2 & #6

The controller cord should be removed.

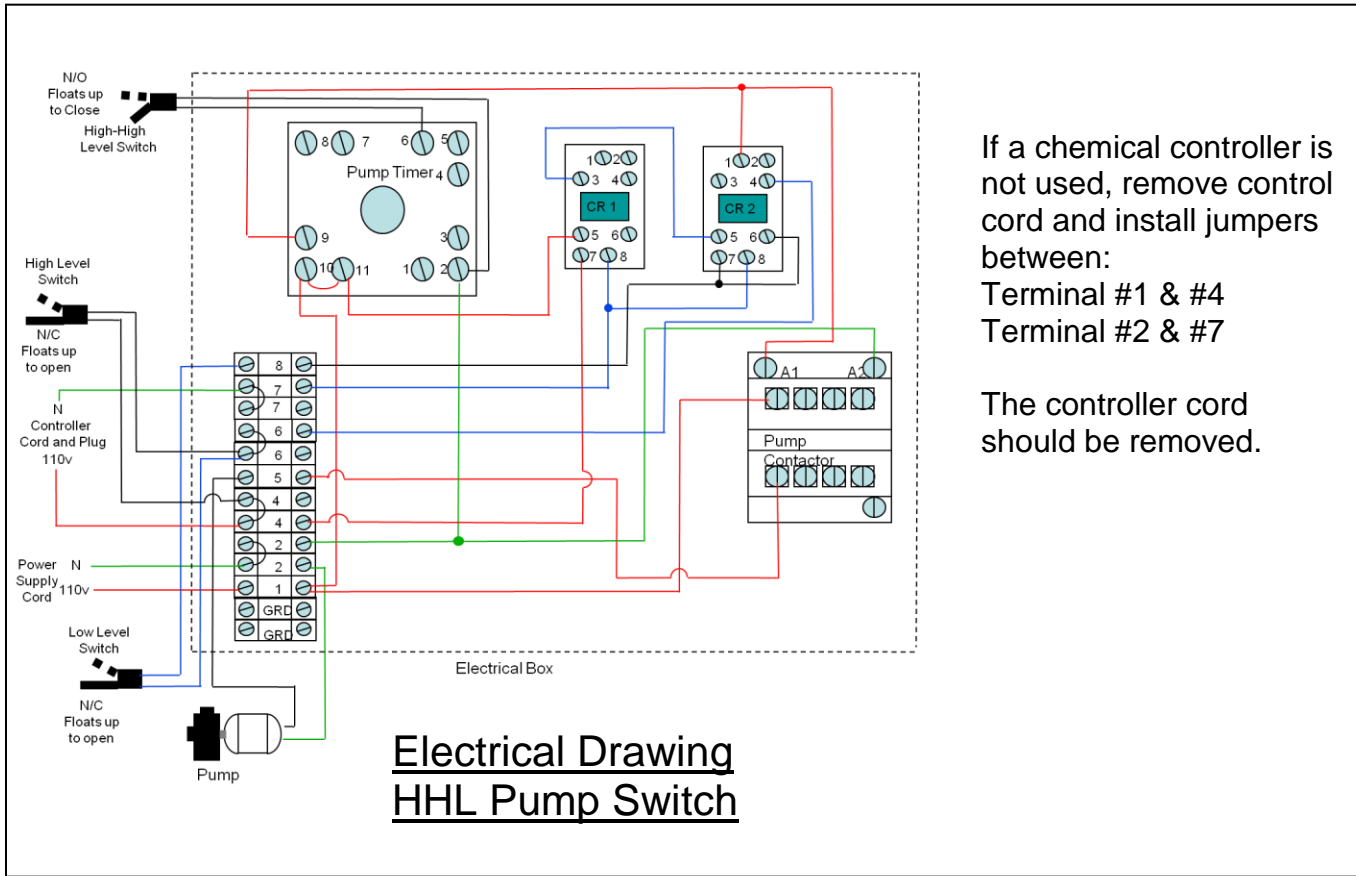

If a chemical controller is not used, remove control cord and install jumpers between:
Terminal #1 & #4
Terminal #2 & #7

The controller cord should be removed.

CAL-HYPO COMMERCIAL SYSTEM LIMITED WARRANTY

Axiall Corporation ("Axiall") warrants (subject to the below conditions) only its title to this water treatment system equipment (the "System") and that the System will be free of defects in materials and workmanship for a period of twelve (12) months from its original installation date. THIS IS THE ONLY REPRESENTATION OR EXPRESS WARRANTY THAT AXIALL MAKES AND ALL OTHER EXPRESS WARRANTIES UNDER STATUTE OR ARISING OTHERWISE IN LAW FROM A COURSE OF DEALING OR USAGE OF TRADE WITH RESPECT TO THE SYSTEM ARE DISCLAIMED. ANY IMPLIED WARRANTIES EXISTING AS A MATTER OF LAW SHALL NOT EXCEED THE DURATION OF THIS LIMITED WARRANTY. IN THE EVENT THE SYSTEM FAILS TO CONFORM TO THIS WARRANTY, AXIALL'S EXCLUSIVE OBLIGATION AND YOUR EXCLUSIVE REMEDY SHALL BE LIMITED TO, AT AXIALL'S OPTION, THE FURNISHING OF NEEDED REPLACEMENT PARTS OR THE FURNISHING OF A NEW SYSTEM (BUT THIS DOES NOT INCLUDE INSTALLATION OR THE COSTS FOR INSTALLATION). EXCEPT AS PROVIDED IN THE IMMEDIATELY PRECEDING SENTENCE, IN NO EVENT WILL AXIALL BE LIABLE UNDER ANY THEORY OF RECOVERY (WHETHER BASED ON NEGLIGENCE OF ANY KIND, STRICT LIABILITY OR TORT) FOR ANY DIRECT, INDIRECT, SPECIAL, INCIDENTAL, PUNITIVE, OR CONSEQUENTIAL DAMAGES IN ANY WAY RELATED TO ANY USE MADE OF THE SYSTEM.

Warranty Conditions. This Limited Warranty shall apply and be effective only if: (i) the Axiall Chlorinator Warranty Registration information has been completed within thirty (30) days of the customer's receipt of the system via the Internet at <http://www.accu-tab.com/WarrantyRegistration.aspx>; (ii) the System is installed and operated and maintained in accordance with this manual and the instructions accompanying the System; (iii) you, at your cost, promptly return the System or defective part to such location as may be specified by Axiall; and, (iv) only Axiall's Accu-Tab® Blue SI calcium hypochlorite tablets are used in the System. If any of these conditions are not met, this Limited Warranty will not apply and you acknowledge and agree that your purchase of the System will be on an "AS-IS" basis without any warranty of any kind whatsoever having been provided by Axiall.

You assume all responsibility and risk and liability arising from: (i) the unloading, installation, storage, handling and use of the System, including use thereof alone or in combination with other materials; (ii) the improper functioning or failure of unloading, installation, transportation or storage equipment you use, whether furnished or recommended by Axiall or not; and, (iii) the failure to comply with laws, rules and regulations governing storage, unloading, installation, handling, and use of the System. You will indemnify, hold harmless, and defend Axiall from and against any claim, suit, damage, cost, expense, fine, liability, or cause of action whatsoever, including reasonable attorney fees, on account of relating to, or arising out of the use, possession, installation or resale of the System.

This Limited Warranty gives you specific rights, and you also may have other rights, which vary from jurisdiction to jurisdiction. Some jurisdictions do not allow the exclusion or limitation of incidental or consequential damages, so the above limitations or exclusions may not apply to you. Some jurisdictions do not allow limitations on how long an implied warranty lasts, so the above limitation may not apply to you.